



© 2010 Sunbeam Products, Inc. doing business as Jarden Consumer Solutions.
All rights reserved. Distributed by Sunbeam Products, Inc. doing business as
Jarden Consumer Solutions, Boca Raton, Florida 33431.

1-888-skybar9

www.skybarhome.com

Printed in China.

SPR-022210

Part No. 139402 Rev. A



WINE
SYSTEM
MANUAL

IMPORTANT SAFEGUARDS

To reduce the risk of fire, electric shock and/or injury to persons, basic safety precautions should always be followed when using electrical appliances, including the following:

1. **READ ALL INSTRUCTIONS BEFORE USING THE skybar® ONE WINE SYSTEM.**
2. To protect against electric shock, do not immerse the power cord, power plug or skybar® One Wine System in water or in any other liquid.
3. Do not operate the product with a damaged power cord or power plug or after the appliance malfunctions or has been damaged in any manner. Do not return to the place of purchase. Call 1-888-skybar9 for service.
4. The use of accessory attachments other than the manufacturer's brand products may cause hazards or injury.
5. Do not use the skybar® One Wine System outdoors.
6. Do not let the power cord hang near the edge of a table or cabinet or across a doorway. Do not allow the cord or the appliance to rest on or near hot surfaces such as a hot gas or electric burner or a heated oven.
7. Do not place the skybar® One Wine System in direct sunlight.
8. To disconnect the skybar® One Wine System, turn OFF the main power switch located at the back of the unit. Then remove the power plug from the wall outlet. Disconnect skybar® One Wine System when not in use, before user servicing and cleaning.
9. Place the appliance on a hard, flat, stable level surface.
10. Avoid contact with any moving parts.
11. The skybar® One Wine System is designed for household use only.
12. Do not use this product for anything other than its intended use. It should only be used with wine. No other liquids should be used. Liquids with pulp, sugar or syrup will clog the system. Additionally, do not use with champagne or other sparkling wines. The system will remove the bubbles in the champagne and ruin your beverage.
13. **WARNING:** If you are under 21, it is illegal for you to make or consume beer or wine in the United States.

GOVERNMENT WARNING:

- (1) According to the Surgeon General, women should not drink alcoholic beverages during pregnancy because of the risk of birth defects.
 - (2) Consumption of alcoholic beverages impairs your ability to drive a car or operate machinery, and may cause health problems.
14. Risk of electric shock. Do not attempt to open the back of the unit. There are no User Serviceable parts inside. A list of User Serviceable parts has been provided in the User Servicing Section on page 20 of this document.
 15. Use extreme care and supervision when setting up and using the product around children. Place the skybar® One Wine System in a stable location to ensure that it will not fall and cause injury.

SAVE THESE INSTRUCTIONS.

Please Note: Special Cord Set Instruction

- An appropriate-size power cord is provided to reduce the hazards resulting from a person or pet becoming entangled in or tripping over a longer cord.
- An extension cord may be purchased and used if care is exercised in its use.
- If an extension cord is used, the marked electrical rating of the extension cord must be at least as great as the electrical rating of the skybar® One Wine System. Extension cord shall be a grounding-type 3-wire cord. The complete extended cord must be arranged so that it does not hang near the edge of a table or cabinet, across a doorway or allow it to come in contact with hot surfaces.
- The skybar® One Wine System has a grounded three-prong electrical plug. It must be plugged only into a properly grounded three-prong outlet. Do not modify the plug in any way.

WELCOME

Beautifully designed and stylishly functional, the skybar® One Wine System is the perfect accessory for entertaining with wine in your home. Welcome. Enjoy.

PLACING THE UNIT IN YOUR LIVING SPACE

With its contemporary design, the skybar® One Wine System will work well in a number of different spaces in your home. When choosing a location, it is essential to consider how you will use the Wine System.

- **Where do you entertain?**

When choosing a location, think about where you entertain with wine, where you store your barware and how you (and your guests) will use the skybar® One Wine System.

- **Away from heat sources.**

Always place your skybar® One Wine System in a cool location, away from heat registers or radiators.

- **No direct sunlight.**

Choose a location where your skybar® One Wine System will not be exposed to direct sunlight. Direct sunlight will affect the time it takes to chill the bottle and can compromise the chilling effectiveness of the unit.

- **Convenient power source.**

Note the need to access a 120V power outlet.

- **Stability is critical.**

For maximum stability, choose a level and secure location within your home. Avoid hallways, tight passages or high traffic areas.

- **Minimum 2-inch space buffer.**

DO NOT place the skybar® One Wine System tight into a corner or directly up against a wall. You must allow at least 2 inches of space around the unit for optimum performance.

- **Consider spills.**

Since wine drinkers will gather around the system, consider accidental spills on carpet, furniture or accessories in the area.

Chill – Serve your favorite wine at its ideal temperature

- Take the guesswork out of wine chilling.

With preset temperatures for 15 popular wine varietals (i.e. Sauvignon Blanc 45°F, Chardonnay 50°F, etc.), the skybar® One Wine System automatically cools the bottle to the ideal serving temperature – taking the guesswork out of wine serving.

- Adjust the temperature to your personal preference

Like your Chardonnay a bit cooler? Simple manual temperature controls allow you to adjust the temperature to your personal liking.

Pour – Sample one perfect glass at a time.

- The right temperature – every time.

Once the chamber has reached the preset temperature, pour directly into your glass. Each glass is served at the ideal temperature for the varietal setting you select.

Preserve – Now you can enjoy your favorite bottle of wine longer

- Wine stays fresh up to 10 days

Natural vacuum technology automatically preserves the open bottle for up to 10 days by removing oxygen that would otherwise oxidize and ruin the wine. No need for manual pumps, gasses or cartridges.

- Open the wine you want

Open that special bottle you'd like to enjoy now, without worrying about wasted wine if you don't finish the bottle.

Metropolitan Design – A sleek and elegant accessory for your home.

- Form meets function.





The skybar® One Wine System is not only beautiful, it also offers the unique Chill | Pour | Preserve functionality. Perfect for entertaining.

- Place it virtually anywhere.

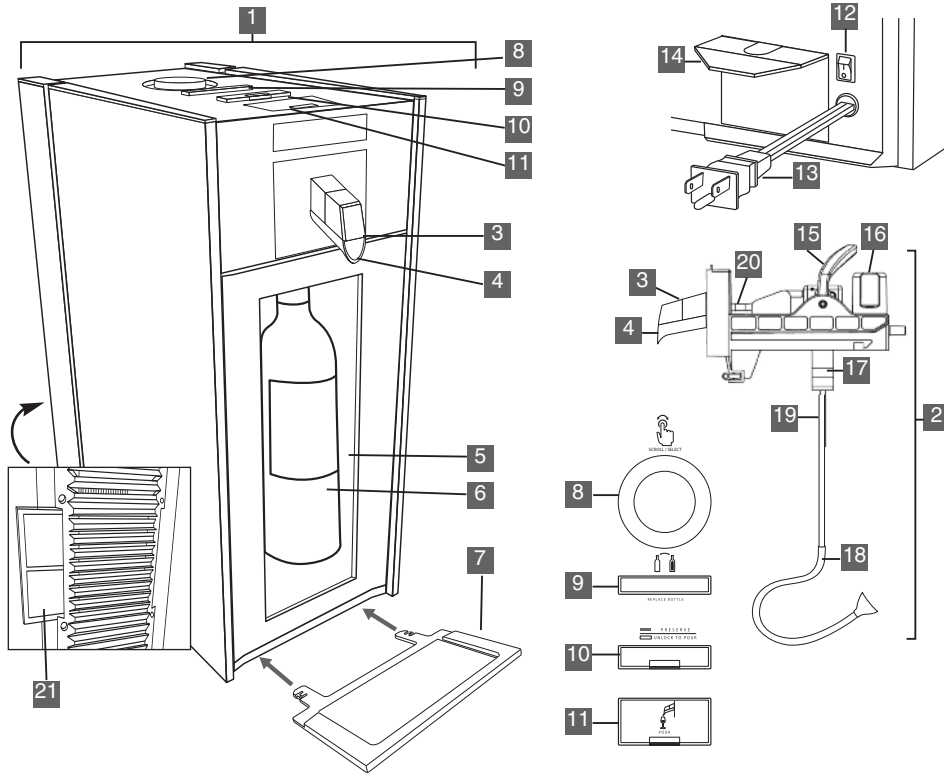
From spacious suburban homes to modern urban lofts, the skybar® One Wine System is at home in the kitchen, living room, dining room or bar.

skybar® One Wine System Diagram of Parts



- | | |
|--|-------------------------------------|
| 1. Wine System | 12. Main Power Button |
| 2. Bottle Pour Assembly | 13. Power Cord |
| 3. Pour Tip (with O-ring) | 14. Condensation Tray |
| 4. Pour Spout | 15. Bottle Lock Lever |
| 5. Chamber Door | 16. Reserve Cup |
| 6. Chilling Chamber | 17. Bottle Stopper |
| 7. Drip Tray | 18. Bottle Tube (lower) with filter |
| 8. Control Knob  | 19. Bottle Tube (upper) |
| 9. Replace Bottle Button  | 20. Pour Tube |
| 10. Preserve/Unlock to Pour Button  | 21. Air Filter (back) |
| 11. Pour Button  | |

SETUP

After choosing an appropriate location within your home and safely placing the skybar® One Wine System, it is time to set up your skybar® One Wine System.

- Before using the skybar® One Wine System for the first time, rinse the Bottle Pour Assembly. The Bottle Pour Assembly is fully submersible, and can be washed by hand. (DO NOT PUT IN DISHWASHER – NOT DISHWASHER SAFE.). Soap can noticeably affect the flavors of fine wine, which is why most wine connoisseurs simply give their glasses a hot water rinse. With this in mind, it is recommended that you clean the Bottle Pour Assembly with a thorough hot water flush. Rinse until you see water run clear. Dry with a soft cloth or paper towel or allow to air dry.

- To attach the glass door to the unit:
 - Carefully remove the glass door from its protective packaging. Be sure to place the door on a soft padded surface so the glass is not scratched.

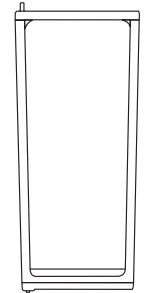

Figure A

- Identify the top end (short side) of the glass door that contains the "longer hinge pin" and hold the door to position this pin in the upper left corner. (See Figure A.) Grasp the door securely to ensure you do not drop it.

- Carefully insert the long hinge pin fully up into the upper hinge mount located on the front of the skybar® One Wine System. (See Figure B.)

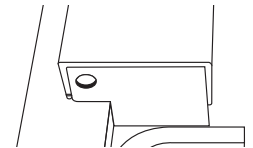

Figure B

- After the upper hinge pin is fully inserted, carefully move the lower hinge pin into place, allowing it to securely rest into the lower hinge mount located on the front of the skybar® One Wine System. (**Note:** The lower hinge pin can most easily be inserted into the lower hinge mount if the hinge pin is brought into place from the FRONT RIGHT SIDE of the hinge mount. (See Figure C.)

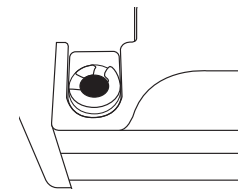

Figure C

SETUP

- e. Before releasing the door, check to ensure the door is securely seated into the hinge mounts. The door should now swing open and close freely.
3. Plug the unit into a 120V power outlet.
 4. Switch the Main Power Button – located in the back of the unit – to “on.”
 - After the unit is switched on (with the door installed and closed), you will hear the Chilling Chamber cycle on and begin to chill and attempt to preserve. If there is no bottle in place, the preservation cycle will stop automatically after several seconds.
 - The Chilling Chamber is factory pre-set to a temperature of 50°F/10°C. When installing a bottle, you can select the temperature you prefer. (See Setting the Temperature on page 13.)
 - If the temperature in your home rises above 80°F/27°C or 60% relative humidity for an extended period of time, there is a possibility that excessive condensation will occur. **Please check the water level in the removable Condensation Tray regularly in warm, humid environments.** If you will be away from your home for more than one week, we recommend that you remove wine bottles from the chamber and turn the unit OFF during your absence.
 5. The drip tray attaches to the front bottom of your skybar® One Wine System, below the bottom of the chamber door and slides underneath the unit and clicks into place. The drip tray protects table surfaces from the last drop of wine that may occur after pouring. For best results, when pouring wine, hold your glass a second longer under the pour spout after releasing the pour button to catch this last drop.

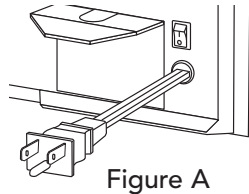

Figure A

INSTALLING BOTTLES

INSTALLING OR REPLACING THE WINE BOTTLE

1. Open the Chilling Chamber door.
2. Grasp the Pour Spout (or the wine bottle if there is already a bottle in place), then press the Replace Bottle Button at the top of the unit. This will release the Bottle Pour Assembly locking mechanism. (See Figure B.)
3. Slide the Bottle Pour Assembly forward until it has cleared the chamber opening. (See Figure C.)
 - a. If the Chilling Chamber was empty, carry the Bottle Pour Assembly to the kitchen.
 - b. If the Bottle Pour Assembly already has a bottle attached:
 - i. Support the bottom of the bottle when transporting the bottle and Bottle Pour Assembly to the kitchen. (See Figure D.)
 - ii. To avoid spills, do not unlock the Bottle Pour Assembly from the bottle until you are over a sink or countertop.
 - iii. Unlock the Bottle Pour Assembly from the empty bottle.
4. Always thoroughly rinse the Bottle Pour Assembly and clean the Pour Tip between bottles. (Refer to Care and Cleaning on page 18 for more information.)
5. Uncork the bottle of wine and remove the foil wrap around the bottle neck. **Please note:** This system is optimized for use with wine bottles that utilize corks. It may be used with some, but not all, bottles that use a screw cap closure. Visit skybarhome.com to view the adaptor available for screw cap bottles.

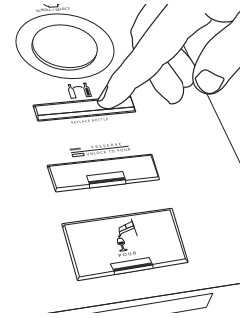

Figure B

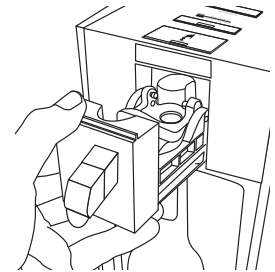

Figure C

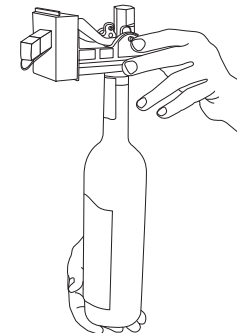

Figure D

SUGGESTION

EXCHANGE BOTTLES WITHOUT MAKING A MESS.

To avoid spills, always work over a sink when attaching or detaching the Bottle Pour Assembly from a wine bottle.

INSTALLING BOTTLES

6. Taste a sample of the wine to ensure the wine is of desired quality.
7. Check the inside of the bottle neck to ensure no loose pieces of cork or foil will obstruct the seal between the bottle neck and the Bottle Pour Assembly.
8. Lift the Bottle Lock Lever into the vertical (open) position. (See Figure E.)
9. Place the Bottle Tube fully into the bottle. Ensure the rubber bottle stopper at the top of the Bottle Tube is fully and firmly inserted into the bottle.
10. Press the Bottle Lock Lever downward into the horizontal (closed) position to lock the Bottle Pour Assembly to the wine bottle. (See Figure G.)
 - a. Gently tug upward on the Bottle Pour Assembly to confirm that it is securely mounted to the bottle.
11. Securely supporting the bottom of the wine bottle with your hand, transport the bottle with the Bottle Pour Assembly to your skybar® One Wine System.
12. Continuing to support the bottle from the bottom, open the chamber door and slide the Bottle Pour Assembly into the unit until you hear it lock into place. (See Figure C.)
13. Close the Chilling Chamber door.

SUGGESTION

INSPECT THE BOTTLE.

Inspect the neck to ensure it is free of cork or foil debris before loading the bottle into the skybar® One Wine System.

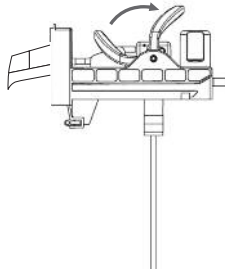

Figure E

SUGGESTION

TASTE WINE BEFORE SERVING.

Always sample a bit of wine before loading a new bottle into the skybar® One Wine System to ensure the bottle is satisfactory to your tastes.

- The Preserve/Unlock to Pour button light will blink while you hear the preservation process begin. The amber light will stop blinking and will remain lit once the wine has reached the preservation mode.

INSTALLING BOTTLES

- The Chilling Chamber will automatically begin chilling the wine to the default setting of 50°F/10°C. To adjust the temperature to another setting, press and rotate the Control Knob on the top of the unit to select another wine varietal setting or a specific temperature.
- For optimum performance, keep the Chilling Chamber door closed while in operation.

Note: If the door is left open, the chamber will automatically shut off after one hour.

SUGGESTION

FACE THE LABEL FORWARD.

To showcase your wine, turn the bottle so the label is facing the front before locking the Bottle Pour Assembly in place.

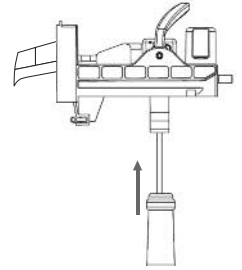

Figure F

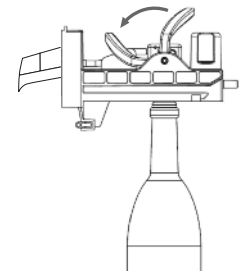

Figure G

A NOTE ABOUT WINE PRESERVATION

Once a bottle of wine has been uncorked, oxygen comes into contact with the wine and begins a chemical change called oxidation. Once oxidation begins, it cannot be stopped but, fortunately, it can be slowed! The Wine System removes oxygen from the bottle, slowing the rate of oxidation and keeping your wine preserved for a longer period of time.

Different wines will oxidize at different rates. For this reason, it is difficult to predict exactly how long a specific wine will last, even with preservation techniques. Some wine will naturally oxidize more quickly. Wine is best enjoyed within ten days after opening.

Using the Control Knob located on the top of the skybar® One Wine System, you can:

- View the Current Set Temperature
- Turn the Chamber light ON or OFF
- Set the Temperature by 15 pre-set Wine Types or to a specific temperature of your choosing.

Note: The “Chill Status” is always displayed when the unit is ON, showing either “Chilling” or “Ready.” The panel will illuminate to 100% brightness during user interaction, and reduced illumination during stand by.

1. Press the Control Knob. You will see <MENU OPTIONS > displayed. (See Figure A.)
Note: If you rotate the Control Knob first, you will be prompted to PRESS FOR MENU. (See Figure B.)
2. Rotate the Control Knob either clockwise or counter-clockwise to see the various feature options:
 - a. VIEW SET TEMP.
 - b. SET BY WINE TYPE
 - c. SET BY TEMP.
 - d. TURN LIGHT ON or OFF
3. When you see the desired menu option, press the Control Knob to select that option.
Note: If no option is selected, the display will return back to standby mode after 30 seconds.
4. TO VIEW SET TEMP.
Rotate the Control Knob and press when VIEW SET TEMP is displayed.(See Figure C.)
 - a. The current SET temperature will be displayed for 5 seconds before the display returns to the chill status indication of CHILLING or READY.



Figure A

PRESS FOR MENU

Figure B



Figure C

SETTING THE TEMPERATURE

5. SET BY WINE TYPE

Rotate the Control Knob and press when SET BY WINE TYPE is displayed. (See Figure D.)

- Rotate the knob clockwise or counter-clockwise to cycle through the various varietal pre-set options.
- Once the desired varietal is displayed, press the knob to set the Chilling Chamber to that setting. (See Figure E.)
- The save setting will be displayed and the new SET temperature will flash for 5 seconds.
- The Chilling Chamber will begin to cool to the desired temperature and the display will show the Chill Status (CHILLING or READY). When the chamber has reached the SET temperature, the display will change to READY. (See Figure F.)



SET BY WINE TYPE

Figure D

CHARDONNAY 50°F

Figure E

READY

Figure F



SET BY TEMP.

Figure G

< 50°F >

Figure H

6. SET BY TEMP.

To set the Chilling Chamber to a specific temperature, rotate the Control Knob and press when SET BY TEMP is displayed. (See Figure G.)

- The display will show the default temperature of 50°F/10°C or the previously Set Temperature. (See Figure H.)
- Rotate the Control Knob clockwise or counter-clockwise to select from the temperature options, ranging from 45°F/7°C to 68°F/20°C.
- Once the desired temperature is displayed, press the Control Knob to save the setting.
- The selected temperature will be displayed and the new SET temperature will flash.

SETTING THE TEMPERATURE

7. TURN LIGHT ON or OFF

Rotate the Control Knob and press when TURN LIGHT ON [or OFF] is displayed. (See Figure I.)

- Pressing the Control Knob will change the status of the light – ON or OFF.

TURN LIGHT ON

Figure I

TEMPERATURE PRESETS

WINE VARIETAL PRESET TEMPERATURES

Wine	Temperature
Sauvignon Blanc	45°F/7°C
Chablis	45°F/7°C
Fumé Blanc	45°F/7°C
White Burgundy	45°F/7°C
Rosé	45°F/7°C
Pinot Grigio	45°F/7°C
White Zinfandel	45°F/7°C
Chardonnay	50°F/10°C
Pinot Noir	55°F/13°C
Chianti	60°F/16°C
Merlot	60°F/16°C
Bordeaux	65°F/18°C
Cabernet Sauvignon	65°F/18°C
Shiraz/Syrah	65°F/18°C
Zinfandel (Red)	65°F/18°C

For recommended serving temperatures for additional wine types, please visit skybarhome.com. Personal preferences may vary.

Important note:

- Total chilling time will vary based on the initial temperature of the bottle, the room temperature and the Chilling Chamber Set temperature. "Ready" will appear on the LCD display when the wine has reached a desirable drinking temperature.

SETTING THE TEMPERATURE

CHANGING TEMPERATURE SCALE

The skybar® One Wine System allows you to select between the Fahrenheit (F) or Celsius (C) temperature scale.

- Press and hold the Control Knob for 3 seconds. SELECT TEMP. SCALE will appear in the display. (See Figure A.)
- Rotate the knob clockwise or counter-clockwise to toggle between Fahrenheit and Celsius.
- Once the desired scale is displayed, press the Control Knob to save the desired setting.



Figure A

For Optimum Performance

- Close the door, the display will indicate if a door is left open. After 60 minutes, if the door is left open, the chilling function will shut off.

Important note:

For optimum cooling, thermoelectric products like the skybar® One Wine System should be in an environment with a room temperature 72°F/22°C or less. A higher room temperature will result in a slightly warmer internal chamber temperature.

Please reference below chart for approximate room temperatures and the resulting coldest internal wine chamber temperatures:

Approx. Room Temperature	Approx. Internal Wine Chamber Temperature
72°F/22°C	45°F/7°C
74°F/23°C	47°F/8°C
76°F/24°C	49°F/9°C

POURING WINE

POURING WINE

The skybar® One Wine System chills, pours and preserves your wine so it is ready to enjoy...one perfect glass at a time. The buttons that control preservation and pouring are located on the top of the unit.

1. When the amber light is illuminated on the "Preserve/Unlock to Pour" Button, the Chilling Chamber is in preservation mode.
2. Simply press the "Preserve/Unlock to Pour" to enable the Pour feature. (See Figure A.)
3. A solid green indicator light on the "Pour Button" will indicate that the bottle is ready to pour. Be sure the chamber door is closed and remains closed before you pour.
4. Hold the glass under the Pour Spout before pressing the Pour Button; wine will begin to flow when you press the button.
5. Press and hold the Pour Button to pour wine. Never open the chamber door while pouring wine.
6. When you have finished pouring, release the Pour Button and allow the last drop to flow into your glass before pulling it away from the Pour Spout.

- The green Pour Button indicator light will remain lit, and additional glasses can be poured.
- The bottle will automatically return to preservation mode after 30 minutes of inactivity. Or, you can manually return the bottle to preservation mode by pressing the "Preserve/Unlock to Pour" Button. The blinking amber light will indicate that the unit is returning to preservation mode.

Please note: Many wines contain sediment that settles in the bottom of the bottle. The skybar® One Wine System is designed to leave a small amount of wine in the bottom of every "finished" bottle to avoid dispensing this unwanted sediment.

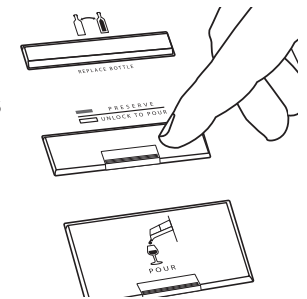

Figure A

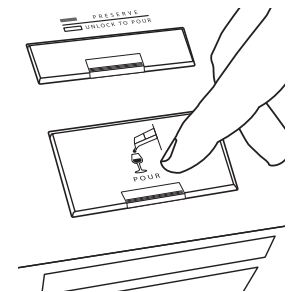

Figure B

SUGGESTION
SAVOR EACH DROP.
 Don't waste a drop of your favorite wine. Be sure to release the Pour Button and wait a moment or two before moving your glass away from the Pour Spout.

CARE AND CLEANING

To ensure optimal performance, it is important to properly clean and care for your skybar® One Wine System. Follow these recommendations to eliminate cross-contamination of wine flavor and maintain optimal performance.

BEFORE CLEANING: Switch off and disconnect skybar® One Wine System. Do Not Immerse.

Exterior Care

1. Clean the exterior housing with a slightly damp cloth. (NEVER use an abrasive cleaner on the exterior.)
2. Very special care should be exercised when cleaning a high polished cabinet exterior, avoid using an abrasive sponge or cleaning pad, as this may scratch and damage the unit.
3. Clean the Chilling Chamber glass door with a household glass cleaner.
4. Clean the Control Panel, the Pour Spout and surrounding area and all buttons with a slightly damp cloth. Liquids should never be poured or sprayed near buttons or on or near the Pour Spout or Control Panel.
5. The interior of the Chilling Chamber and the rear panel can also be cleaned with a slightly damp cloth.
6. There is an air filter located at the back of the unit, occasionally remove and rinse with water, let air-dry and then reinstall.

Bottle Pour Assembly Care

1. The Bottle Pour Assembly is fully submersible and can be safely cleaned with water. We recommend that you do not use soap, which can noticeably affect the flavors of fine wine. Many wine connoisseurs simply give their glasses a hot water rinse. With this in mind, it is possible – and recommended – to clean the Bottle Pour Assembly with a thorough hot water flush.

DO NOT PUT IN DISHWASHER: NOT DISHWASHER SAFE.

2. We recommend that you rinse the Bottle Pour Assembly between each bottle of wine, especially when changing from one type of wine to another. This prevents cross contamination of wine flavor between different types of wine.

3. Lift the Bottle Lock Lever into the vertical (open) position (See Figure E, pg. 10) and remove the bottle Pour Assembly from the empty bottle. There may be some residual wine in the tube so carefully carry to a sink to clean.

- Remove the Pour Tip by sliding it out from the Pour Spout. This will allow any remaining liquids to flow out and air and water to pass through the Bottle Pour Assembly for cleaning. (DO THIS OVER THE SINK.)

Note: We recommend that occasionally you soak the Pour Tip in warm water for about 1 hour between bottle changes.

- Run the Bottle Tube under the water faucet, causing water to flow through the Bottle Pour Assembly and out the Pour Spout.
 - There is a filter located at the bottom of the Bottle Tube to keep sediment from clogging the system. When cleaning, be sure to run water through this filter to clear any sediment that may remain.
 - The Bottle Pour Assembly features a Reserve Chamber that captures any wine that may be inadvertently drawn into the vacuum system. To clean this reserve area, simply unscrew the bottle from the Bottle Pour Assembly, rinse with warm water and air dry.
4. Shake the Bottle Pour Assembly. Dry with a soft cloth or paper towel or allow it to completely air dry.

Note: Always be sure to securely replace the Pour Tip onto the Bottle Pour Assembly by sliding it back into place into the Pour Spout, ensuring the O-ring seal is intact.

Air Filter Cleaning Care

For optimum performance, the Air Filter should be removed, clean with warm running water, and dried properly prior to re-assembly. However, if you forget, the Skybar One Wine System was designed with intelligence to remind you and will flash a message “Clean Filter” on the LCD screen. After the filter is cleaned and replace, reset the counter by pushing the main Control Knob down for over 1 second.

SUGGESTION

HIGH AND DRY.
After cleaning the Bottle Pour Assembly, allow it to dry completely to ensure that no water dilutes your next bottle of wine.

TROUBLESHOOTING

Your skybar® One Wine System has been carefully designed to give you many years of trouble-free service. In the unlikely event that your skybar® One Wine System does not operate satisfactorily, please review the following potential problems and try the steps recommended BEFORE you call an authorized service center.

To order replacement parts or for additional help with product questions, please call 1-888-SKYBAR9 (1-888-759-2279).

Problem	Recommended Steps
Power	
The Wine System does not turn on.	<ul style="list-style-type: none"> • Ensure that the Wine System is plugged into an outlet. • Ensure that the outlet has power. • Ensure that the power button on the back of the unit is "On".
Lights are flashing (Amber and Green) with no bottle installed.	<ul style="list-style-type: none"> • Open and close the Chilling Chamber door to reset. • Remove the Bottle Pour Assembly and wash it thoroughly then replace. • Ensure that the Pour Tip and Reserve Cup are securely seated in place.
Display	
Nothing is shown on the display window.	<ul style="list-style-type: none"> • Ensure that the Main Power Button is "On" and that there is power to the unit. (See SETUP.)
Dispensing/Pouring	
Pressing the Replace Bottle Button does not release the Bottle Pour Assembly.	<ul style="list-style-type: none"> • Open door first, press and hold the Replace Bottle Button, reach into the Chilling Chamber and gently lift upward and pull the Bottle Pour Assembly toward you.

Problem	Recommended Steps
Dispensing/Pouring	
Wine is not pouring smoothly.	<ul style="list-style-type: none"> • Remove and clean the Pour Tip over a sink.
Wine does not pour when the Pour Button is pressed.	<ul style="list-style-type: none"> • Ensure that the wine bottle is installed correctly onto the Bottle Pour Assembly and that the Bottle Pour Assembly is securely engaged into the Chilling Chamber. (See page 9.) • Press the Pour Button when the green light is illuminated. • <i>Note: If the green light is not illuminated and the amber light is illuminated, press the Preserve/Unlock to Pour Button, which will stop preservation, turn off the amber light and enable pouring, indicated by the green light. (See page 17.)</i> • Ensure that the Pour Tip is securely installed onto the Pour Spout. • Wine will not dispense if the chamber is actively in the preservation mode. <ul style="list-style-type: none"> – Wait for the preservation cycle to be completed, or – Cancel the preservation process by pressing the Preservation Button.
A wine bottle is securely installed but preservation mode is not working.	<ul style="list-style-type: none"> • If a wine bottle is installed, the lights should be amber or green. If no lights are illuminated, neither the preservation mode nor the pour mode is active. • Open the Chilling Chamber door and ensure the bottle is installed correctly onto the Bottle Pour Assembly and that the Bottle Pour Assembly is engaged into the Chilling Chamber. Close the door, and the system should reset.

Problem	Recommended Steps
<p>Dispensing/Pouring</p> <p>A wine bottle is securely installed but preservation mode is not working.</p>	<ul style="list-style-type: none"> • Ensure the Pour Tip is securely in place on the Pour Spout. If you have reinstalled the Pour Tip, reset the preservation mode by opening and closing the door after you have reinstalled the Pour Tip. Preservation should begin and the amber light should illuminate. (See page 17.) • Remove the Pour Tip by sliding it out from the Pour Spout. This will allow any remaining liquids to flow out and air and water to pass through the Bottle Pour Assembly for cleaning. (DO THIS OVER THE SINK.)
<p>Wine is pouring slowly</p>	<ul style="list-style-type: none"> • Ensure that the wine bottle is installed correctly onto the Bottle Pour Assembly and that the Bottle Pour Assembly is securely engaged into the Chilling Chamber. • Ensure that the Pour Tip is installed onto the Pour Spout properly and is securely tightened. • Clean the Bottle Tube and the Pour Tip by running clean water through the system or following the cleaning instructions. (See page 18.) Dry all parts and reinstall. • Replace the Pour Tip and reset the Chilling Chamber function by opening and closing the door.
<p>The Pour Tip drips or has turbulent flow.</p>	<ul style="list-style-type: none"> • Ensure that the Pour Tip is installed onto the Pour Spout properly and is securely tightened. • Clean the Pour Tip. (See page 18.) • Replace the Pour Tip and reset the Chilling Chamber function by opening and closing the door.

Problem	Recommended Steps
<p>Dispensing/Pouring</p> <p>There are bubbles moving from the Bottle Tube into the bottle of wine.</p>	<p>Note: <i>The skybar® One Wine System is attempting to preserve your wine, but the seal is not closed, which is essential to enabling it to preserve.</i></p> <ul style="list-style-type: none"> • Ensure that the Pour Tip is securely tightened to the Pour Spout. • Ensure that the O-ring is in place on the Pour Tip. If the O-ring is missing, you will need to replace the Pour Tip. • Clean the O-ring and the Pour Spout and recheck the seal.
<p>The wine bottle will not securely install onto the Bottle Pour Assembly.</p>	<ul style="list-style-type: none"> • Ensure that the Bottle Lock Lever is in the vertical (open) position, enabling you to insert the Bottle Tube fully into the bottle. • Press the Bottle Lock Lever into the horizontal (closed) position to engage it to the bottle. • If your wine bottle has a screw cap and not a cork, use the Bottle Adaptor provided by installing it into the bottle first and then insert the Bottle Pour Assembly. <p>Note: Remember to remove the Bottle Adaptor from the Bottle Pour Assembly when the bottle is empty. It can be reused multiple times.</p>
<p>Bottle Will Not Fit</p> <p>The bottle is secured to the Bottle Pour Assembly, but will not fit into the Chilling Chamber.</p>	<ul style="list-style-type: none"> • Some unusually sized bottles – either very tall or very wide – may not fit into the Chilling Chamber, which is sized for standard 750ml bottles.

USER SERVICEABLE PARTS AND INSTALLATION

User Serviceable Parts

1. Air Inlet Filter
2. Chamber Door Assembly
3. Bottle Pour Assembly
4. Refresh Kit: 1 Set: Pour Tip with O-ring Seals,
Short Pour Tube and Long Bottle Tube

All parts are available at skybarhome.com, as well as our unique skybar wine accessories, that will complement your wine system or make a perfect gift for any wine lover.

SERVICE AND MAINTENANCE

If your skybar™ One Wine System requires service, do not return it to the store where you purchased it. All repairs and replacements must be made by an authorized service center. Please call us at the following toll-free telephone number for service, parts and accessories.

U.S. 1-888-SKYBAR9 (1-888-759-2279)

You may also visit our website at skybarhome.com to contact us. To assist us in serving you, please have the skybar® One Wine System model number and date purchased available when you call. The model number is located next to the master power switch on the back of the unit.

We welcome your questions, comments or suggestions. In all your communications, please include your complete name, address, telephone number and a description of the problem.

ONE-YEAR LIMITED WARRANTY

Sunbeam Products, Inc. doing business as Jarden Consumer Solutions or if in Canada, Sunbeam Corporation (Canada) Limited doing business as Jarden Consumer Solutions (collectively "JCS") warrants that for a period of one year from the date of purchase, this product will be free from defects in material and workmanship. JCS, at its option, will repair or replace this product or any component of the product found to be defective during the warranty period. Replacement will be made with a new or remanufactured product or component. If the product is no longer available, replacement may be made with a similar product of equal or greater value. This is your exclusive warranty. Do NOT attempt to repair or adjust any electrical or mechanical functions on this product. Doing so will void this warranty.

This warranty is valid for the original retail purchaser from the date of initial retail purchase and is not transferable. Keep the original sales receipt. Proof of purchase is required to obtain warranty performance. JCS dealers, service centers, or retail stores selling JCS products do not have the right to alter, modify or any way change the terms and conditions of this warranty.

This warranty does not cover normal wear of parts or damage resulting from any of the following: negligent use or misuse of the product, use on improper voltage or current, use contrary to the operating instructions, disassembly, repair or alteration by anyone other than JCS or an authorized JCS service center. Further, the warranty does not cover: Acts of God, such as fire, flood, hurricanes and tornadoes.

What are the limits on JCS's Liability?

JCS shall not be liable for any incidental or consequential damages caused by the breach of any express, implied or statutory warranty or condition. Except to the extent prohibited by applicable law, any implied warranty or condition of merchantability or fitness for a particular purpose is limited in duration to the duration of the above warranty.

JCS disclaims all other warranties, conditions or representations, express, implied, statutory or otherwise.

JCS shall not be liable for any damages of any kind resulting from the purchase, use or misuse of, or inability to use the product including incidental, special, consequential or similar damages or loss of profits, or for any breach of contract, fundamental or otherwise, or for any claim brought against purchaser by any other party.

Some provinces, states or jurisdictions do not allow the exclusion or limitation of incidental or consequential damages or limitations on how long an implied warranty lasts, so the above limitations or exclusion may not apply to you.

This warranty gives you specific legal rights, and you may also have other rights that vary from province to province, state to state or jurisdiction to jurisdiction.

How to Obtain Warranty Service

If you have any question regarding this warranty or would like to obtain warranty service, please call 1-888-SKYBAR9 or 1-888-759-2279 and a convenient service center address will be provided to you.

In the U.S.A., this warranty is offered by Sunbeam Products, Inc. doing business as Jarden Consumer Solutions located in Boca Raton, Florida 33431. In Canada, this warranty is offered by Sunbeam Corporation (Canada) Limited doing business as Jarden Consumer Solutions, located at 20 B Hereford Street, Brampton, Ontario L6Y 0M1. If you have any other problem or claim in connection with this product, please write our Consumer Service Department.

PLEASE DO NOT RETURN THIS PRODUCT TO ANY OF THESE ADDRESSES OR TO THE PLACE OF PURCHASE.